

ROSBACK COMPANY

INTRODUCING **TRUESCORE-PRO**

*NOW AVAILABLE FOR USE
ON MOST FOLDERS*



ELIMINATE CRACKING
WITH THE TRUESCORE-PRO
FASTER, EASIER,
MORE PRODUCTIVE
INNOVATIVE PATENT PENDING DESIGN

*IDEAL FOR DIGITALLY
PRINTED STOCK*

ROSBACK has been providing world class perforating, scoring, and slitting solutions since 1881. The TrueLine and 240XL series perforators provide quality, cost-effective perforating and scoring solutions that presses or folders cannot match. No wonder thousands of demanding print finishers ask for ROSBACK.

Now add the innovative patent pending design TrueScore-Pro to your ROSBACK Perforator. Produce perfect crack free scores every time.

The TrueScore-Pro is designed for scoring digitally printed stock and any sensitive material. No more outsourcing difficult scoring jobs.

The TrueScore-Pro fits all Rosback perforating and scoring machines. No need to remove the perforator shafts to set up the TrueScore-Pro.

AVAILABLE FOR FOLDERS

Three new models are designed for use on most folders with 25, 30, and 35mm slitting shafts. Enjoy the same easy setup and operation and the same perfect results.

HOW THE TrueScore-Pro WORKS

The upper head holds a color-coded male disc. Each colored disc is selected for a particular weight of stock. The lower head has various female groove widths. When the heads engage, the upper male disc gently stretches the fibers into the female ring, providing a deep, perfect score and crack free fold every time.

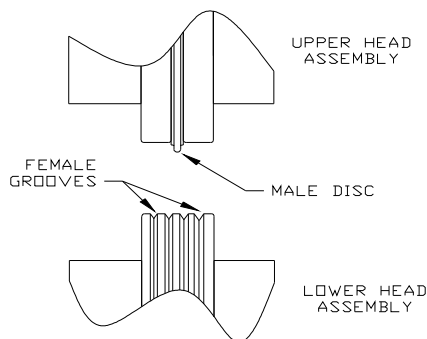

EASY SETUP AND OPERATION

- Choose a female groove width. Determine lower scoring head location for the job and lock into position.
- Choose a male scoring disc. Position the upper head so that the male scoring disc is centered over the chosen lower female groove. Lower the upper head with the pitch control lever. Fasten upper scoring head setscrew.
- Run a sheet through and adjust pressure as normal until the desired score depth is reached.
- To change scoring discs simply unscrew the upper head nut, remove and replace the scoring disc. This can be done with the upper head remaining on the shaft
- The blue disc produces a narrow score, perfect for paper and other light stock materials.
- The black disc produces a medium score.
- The red disc produces a wider score for heavier card and cover stocks.
- Using two standard TrueScore-Pro heads, the minimum line-line spacing is 1-inch. If closer spacing is required, contact ROSBACK with your application and we will provide a solution.
- For perfect bound book covers, consider the TrueScore-Pro Quad (#220-A-206) for use on Rosback machines. These versatile heads create a wide range of spine and hinge covers.

AVAILABLE KITS INCLUDE

- #220-A-203 for Rosback machines
- #TS25-A-010 for 25mm folders
- #TS30-A-010 for 30mm folders
- #TS35-A-010 for 35mm folders

EACH KIT CONTAINS:

- 1-Upper Male Head
 - 1-Lower Female Head
 - 1-Black Male Scoring Disc
 - 1-Blue Male Scoring Disc
 - 1-Red Male Scoring Disc
 - 1-Allen Key for Heads
 - 1-Set Head Wrenches
- Featuring durable and attractive stainless steel hubs and nuts.

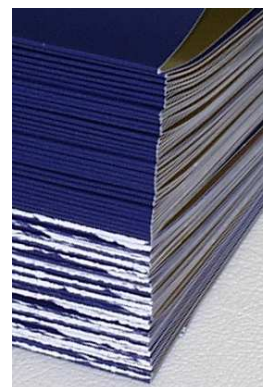

The top of this stack was scored with the TrueScore-Pro while the bottom was scored using standard scoring equipment. The TrueScore-Pro gives dramatically better results.

OTHER ACCESSORIES FOR ROSBACK PERFORATORS

- Quick-Align Perforating Heads
- Slot-Cut Heads. Produce a clean, highly visible and attractive line of perforation in 3 to 12 tpi.
- Knife-Cut Heads. Produce a clean, nearly invisible line of perforation in 3 to 12 tpi.
- Micro-Perf Heads. Very popular for re-feeding printers. Produce a flat, strong perforation that leaves an exceptionally clean edge after separation. Choose 36, 54 or 72 tpi.
- Slitting Heads. Cut multiple forms apart while you score and slit.
- Scoring Heads. Many varieties in stock.
- "CD" Inlay Heads. Produce CD inlay cards in single or multiple formats.
- Gutter Slit/Perf Heads. Slit apart multiple format jobs while ejecting scrap strips from the finished pieces.
- Pressure-Sensitive Slitting Attachment. Back slit or semi-slit labels and decals.
- Narrow Margin Perf Heads (3/8" From Sheet Edge)
- Special Slot-Perf Heads (1/2" Between Perf Lines)
- Easy Out Shafts. Dramatically reduce setup time when tooling changes are required.
- Special Engineered Heads. Chances are good we have done it before and can produce your special application

ROSBACK CO.

125 HAWTHORNE AVE., ST. JOSEPH, MI 49085 USA

Phone: (269) 983-2582 * Fax: (269) 983-2516

Internet: www.rosbackcompany.com * E-mail: sales@rosbackcompany.com

Your Dealer: