

Spare parts list  
Liste de pièces de rechange  
Ersatzteilliste  
Lista de piezas de repuesto  
Lista de peças  
Listino ricambi  
Onderdelenlijst  
Καταλογος ανταλλακτικῶς  
Varaosu luettelo  
Reservdelsliste  
Reservdelfortegnelse  
Reservdelsförteckning

**Rock drills**  
**Marteaux-perforateurs**  
**Gesteinsbohrhämmer**  
**Perforadoras**  
**Martelo perfurador**  
**Perforatrici**  
**Boorhamers**  
**Αεροσφυρες**  
**Kallioporakoneet**  
**Bjergboremaskiner**  
**Bergboremaskiner**  
**Bergbormaskiner**

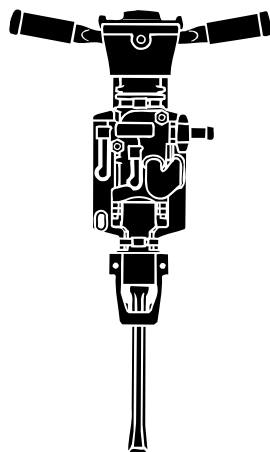

**RH 572E**

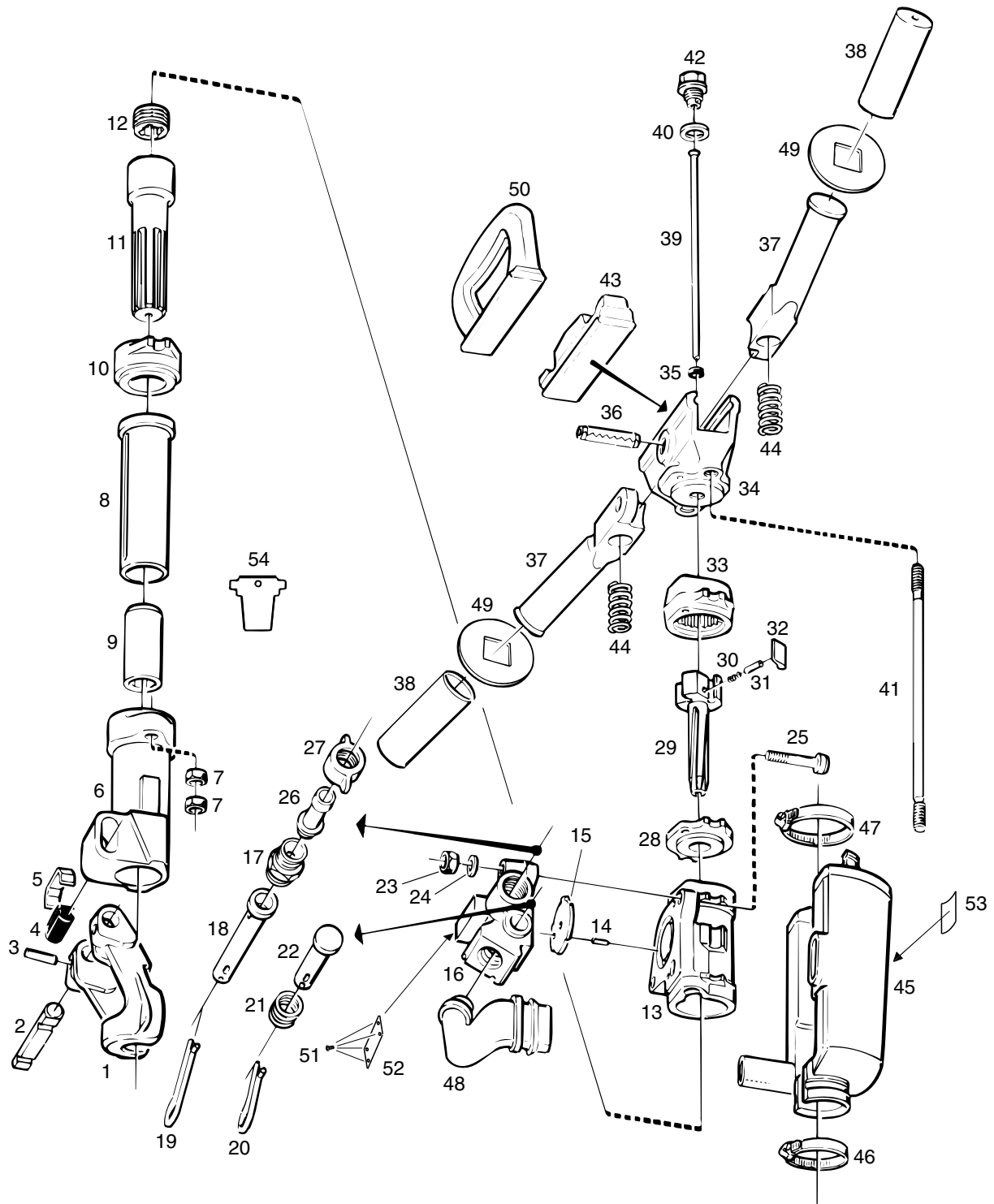

CT11005a

Fig. No. No. de fig. Abb. Nr. Núm de fig. Fig. No No rif. Fig. Nr Αριθ Σχ. Kuva nr. Fig. nr. Fig. nr. Fig. nr.	Ordering No Référéce Bestellnummer Núm. pedido Encomenda No No Cat. Bestel nr. Αριθ. Παραγγελίας Tilaus nro. Bestillingsnummer Bestillingsnummer Best. nummer	Quantity Quantité Anzahl Cantidad Quantidade Quantitá Aantal Ποσότητα Lukumäärä Antal Antal Antal	Description Description Beschreibung Descripción Descrição Descripción Omschrijving Περιγραφή Nimitys Beskrivelse Beskrivelse Beskrivning	Contents Sommaire Inhalt Índice Conteúdo Contenuto Inhoud Περιεχόμενα Sisältö Indhold Innhold Innehåll	Dimensions Dimensions Abmessungen Dimensiones Dimensões Dimensioni Afmetingen Διαστάσεις Mitat Dimensioner Dimensioner Dimensioner
---	--	--	--	---	---

### RH 572E

1	3121 0851 00	1	Drill steel retainer	
2	3121 0852 00	1	Retainer pin	
3	0108 3392 00	2	Tension pin	Ø10x40 mm
4	3121 0030 00	1	Rubber buffer	
5	3121 0029 00	1	Buffer plate	
6	3111 0141 00	1	Front head	
7	0266 1208 00	4	Nut	
-	3111 0185 80	1	Rotation chuck, compl.	H22 x108
8	—*)	1	– Rotation chuck	
9	3111 0186 00	1	– Chuck bushing	H22 x108
10	3111 0143 00	1	Intermediate part	
-	3111 0162 80	1	Piston, compl.	
11	—*)	1	– Piston	
12	3100 9299 08	1	– Rifle nut	
13	3106 0825 00	1	Cylinder	
14	0108 1238 00	1	Spring pin	Ø4x16 mm
15	3101 1586 01	1	Main valve	
-	3115 1163 81	1	Throttle housing, compl.	
16	3115 1163 00	1	–Throttle housing	
17	3115 1924 01	1	– Hexagon nipple	
18	3115 1190 00	1	– Throttle valve	
19	3115 1191 00	1	– Lever	
20	3101 3664 00	1	– Lever	
21	3001 3957 01	1	– Coil spring	
22	3101 4988 00	1	– Exhaust valve	
23	3000 1345 00	2	Nut	
24	0333 3139 00	2	Lock washer	
25	3100 0194 06	2	Bolt	
26	3115 1543 00	1	Hose nipple	3/4"
27	9000 0338 00	1	Wing nut	
28	3106 0827 00	1	Cover	
29	3111 0145 00	1	Rifle bar	
-	3115 9200 90	1	Pawl set, compl	
30	3100 9140 02	4	– Pressure spring	
31	3100 9641 01	4	– Pawl pin	
32	3101 3159 00	4	– Pawl	
33	3115 1167 00	1	Ratchet ring	
34	3115 1885 00	1	Back head	
35	3000 0121 00	1	Rubber packing	
36	0108 1690 37	1	Spring pin	Ø16x70 mm
37	3115 1886 00	2	Handle	

Fig. No. No. de fig. Abb. Nr. Núm de fig. Fig. No No rif. Fig. Nr Αριθ Σχ. Kuva nr. Fig. nr. Fig. nr. Fig. nr.	Ordering No Référéce Bestellnummer Núm. pedido Encomenda No No Cat. Bestel nr. Αριθ. Παραγγελίας Tilaus nro. Bestillingsnummer Bestillingsnummer Best. nummer	Quantity Quantité Anzahl Cantidad Quantidade Quantitá Aantal Ποσότητα Lukumäärä Antal Antal Antal	Description Description Beschreibung Descripción Descriçao Descripción Omschrijving Περιγραφή Nimitys Beskrivelse Beskrivelse Beskrivning	Contents Sommaire Inhalt Índice Conteúdo Contenuto Inhoud Περιεχόμενα Sisältö Indhold Innhold Innehåll	Dimensions Dimensions Abmessungen Dimensiones Dimensões Dimensioni Åfmetingen Διαστάσεις Mitat Dimensioner Dimensjoner Dimensioner
---	--	--	--	---	---

### RH 572E

38	3310 0852 00	2	Rubber sleeve	
39	3111 0140 00	1	Air flushing tube	
40	3100 9341 00	1	Seal washer	
41	3115 1890 00	2	Side bolt	
42	3115 1888 00	1	Plug	
43	3115 2479 00	1	Buffer	
44	3115 1889 00	2	Spring	
-	3115 2485 81	1	Silencer, compl.	
45	3115 2485 80	1	- Silencer	
46	0347 6114 00	1	- Hose clamp	Ø62 - 79 mm
47	0347 6116 00	1	- Hose clamp	Ø77 - 87 mm
48	3115 1141 00	1	- Connecting pipe	
49	3115 2478 00	2	Rubber washer	
51	-*)	1	Data plate	
52	0244 4144 00	4	Screw	
53	0690 1356 00	1	Label	Atlas Copco

### Optional equipment/ Equipement en option/ Sonderzubehör/ Equipos opcionales/ Equipamento opcional/ Attrezzatura opzionale/ Extra uitrusting/ Σετ γενικής επισκευής/ Lisävarusteet/ Ekstra udstyr/ Ekstra utstyr/ Extra utrustning

-	3111 0185 81	1	Rotation chuck, compl.	H19x108
8	-*)	1	- Rotation chuck	
9	3111 0192 00	1	- Chuck bushing	H19x108
50	3115 1914 00	1	Lifting handle	
54	9238 2707 90	1	Gauge	H22

### Synthetic oil AIR-OIL/ Huile synthétique AIR-OIL/ Synthetisches Öl AIR-OIL/ Aceite sintético AIR-OIL/ Sintético óleo AIR-OIL/ Olio sintetico AIR-OIL/ Synthetische olie AIR-OIL/ Συνθετικό λάδι AIR-OIL/ Synteettinen öljy AIR-OIL/ Syntetisk olie AIR-OIL/ Syntetisk olje AIR-OIL/ Syntetisk olja AIR-OIL

	8099 0202 40		Air oil bottle	0.2 l
	8099 0202 36		Air oil bottle	1 l
	8099 0202 02		Air oil container	5 l
	8099 0202 20		Air oil container	25 l
	8099 0202 28		Air oil barrel	200 l

\*) Not delivered separately/ Non disponible en pièces de rechange/ Nicht separat lieferbar/ No se entrega como repuesto/ Non fornibile separatamente/ Não é vendido/ Niet afzonderlijk leverbaar/ Δεν παρέχεται ξεχωριστά/ Ei toimiteta erikseen/Leveres ikke separat/ Leveres ikke som reservdel/ Levereras ej som reservdel

*Use only authorized parts. Any damage or malfunction caused by the use of unauthorized parts is not covered by Warranty or Product Liability.*

*N'utiliser que des pièces approuvées. Tout endommagement ou fonctionnement défectueux résultant de l'utilisation de pièces non approuvées n'est pas couvert par Garantie et responsabilité du produit.*

*Nur zugelassene Teile verwenden. Schäden oder Funktionsstörungen, die auf die Verwendung nicht zugelassener Teile zurückzuführen sind, fallen nicht unter die Garantie- oder Produkthaftungsbestimmungen.*

*Sólo se pueden usar piezas autorizadas. Cualquier daño o funcionamiento defectuoso causado por el uso de piezas no autorizadas no se cubre por la Garantía o la Responsabilidad del Producto.*

*Use apenas peças autorizadas. Qualquer avaria ou mau funcionamento motivado pelo uso de peças não é coberto por garantia ou responsabilidade de riscos causados pelo produto.*

*Usare solamente parti autorizzate. I danni o disturbi del funzionamento causati dall'uso di parti non autorizzate, non sono coperti dalla Garanzia né dall'Assicurazione del prodotto.*

*Gebruik uitsluitend geautoriseerdeonderdelen. Schade of gebreken veroorzaakt door het gebruik van niet-geautoriseerde onderdelen vallen niet onder de garantie of de produkt-aansprakelijkheid.*

*Χρησιμοποιείτε μόνο εγκεκριμένα εξαρτήματα. Τυχόν καταστροφή ή βλάβη η οποία προκαλείται από τη χρήση μη εγκεκριμένων εξαρτημάτων δεν καλύπτεται από την Εγγύηση ή την Ευθύνη Προϊόντος.*

*Käytä vain hyväksytyjä varaosia. Takuu ja tuotevastuu eivät korvaa hyväksymättömien varaosien käytöstä aiheutuvia vaurioita tai toimintahäiriöitä.*

*Brug kun autoriserede dele. Enhver skade eller fejlfunktion, der skyldes brugen af ikke-autoriserede dele, er ikke dækket af garantien eller produktansvarsforsikringen.*

*Brak bare godkjente deler. Enhver skade eller funksjonsfeil som skyldes bruk av ikke godkjente deler dekkes ikke av garanti eller produktansvar.*

*Använd endast godkända reservdelar. Skada eller funktionsfel som beror på användning av ej godkända reservdelar täcks inte av garantiåtaganden eller produktansvar.*

*Any unauthorized use or copying of the contents or any part thereof is prohibited. This applies in particular to trademarks, model denominations, part numbers and drawings.*

*Toute utilisation ou reproduction non autorisée du contenu, ou d'une partie du contenu, est illicite. Cela s'applique particulièrement aux marques déposées, aux désignations de modèles, aux numéros de pièces et aux plans.*

*Unbefugter Gebrauch oder das Kopieren des Inhalts, auch auszugsweise, ist verboten. Dies gilt besonders für Warenzeichen, Modellbezeichnungen, Teilnummern und Zeichnungen.*

*Está prohibido cualquier uso o copia no autorizada del contenido o de cualquier parte de éste. Esto se aplica en especial a marcas registradas, denominaciones de modelos, números de piezas y dibujos.*

*Qualquer utilização não autorizada ou cópia de qualquer peça é expressamente proibida. Isto aplica-se em particular ás marcas registadas, denominação dos modelos, referência de peças e desenhos.*

*E' vitata qualsiasi forma d'uso o copiatura non autorizzata del contenuto, anche parziale, con particolare riguardo ai marchi di fabbrica, alle denominazioni dei modelli, ai numeri delle parti ed ai disegni.*

*Niet-geautoriseerd gebruik of kopiëren van de inhoud of een deel daarvan is niet toegestaan. Dat geldt in het bijzonder voor handelsmerken, model-benamingen, onderdeel nummers en tekening.*

*Τυχόν μη εξουσιοδοτημένη χρήση ή αντιγραφή των περιεχομένων οποιουδήποτε μέρους του παρόντος απαγορεύεται. Αυτό ισχύει ιδιαίτερα στα σήματα κατατεθέντα, τις ονομασίες μοντέλων, τους αριθμούς ανταλλακτικών και τα σχεδιαγράμματα.*

*Sisällön tai sen osan luvaton käyttö tai kopiointi on kielletty. Tämä koskee erityisesti tavaramerkkejä, mallien nimiä, osanumeroita ja piirustuksia.*

*Enhver ikke-autoriseret brug eller kopiering af indholdet eller nogen del deraf er forbudt. Dette gælder især varemærker, modelbetegnelser, reservedelsnumre og tegninger.*

*Enhver ikke godkjent bruk eller kopiering av innholdet eller noen del av det er forbudt. Dette gjelder i særlig grad varemerker, modellbetegnelser, delnummer og tegninger.*

*Ej i förväg godkänd användning eller kopiering av innehållet eller del av detta är förbjuden. Detta gäller speciellt varumärken, modellbeteckningar, reservdelsnummer och ritningar.*